



FREESTANDING WALL INSTALLATION INSTRUCTIONS

BASE COURSE

Since the 6-inch units are palletized together, it is easiest to use both the 6" x 16" and 6" x 8" units to build the base. This will help maintain the ratio of one to one with the blocks and will eliminate the need to pick through the smaller blocks on the pallet, thus saving time. Flip the units over so the lug is down when building the base.

ADDITIONAL COURSES

When building additional courses, use pattern if desired. Alternate blocks so the lug is up or down as needed to maintain vertical wall.

FREESTANDING WALL CORNERS

A freestanding wall corner would typically be built by putting a column in the corner and building away from it. An alternative is to miter a series of blocks to create the corner. Begin with a 16-inch unit. Use a speed square to mark a 45-degree angle off the formed edge on top of the block from the corner to the back of the block. Make the cut and repeat.

On the second course, use an 8-inch unit to stagger the bond. Mark and cut in the same fashion. Fill in the inside corner with two 16-inch pieces by cutting the corners off. You may flip units over or knock off the locator if needed to fit the blocks. All units should be glued bottom to top.

WALL ABUTTING A COLUMN

When abutting the wall in the middle of the column face, some sculpting of the blocks will give a clean, finished look to a project. To eliminate gapping between the freestanding wall blocks and the column unit, mark or scribe the freestanding wall block to fit the face of the column unit into the edge of the wall unit. This is easily achieved with a small handheld grinder with a diamond blade.

CAPPING

The double-sided cap has a right-angle side and an offset-angle side. The caps can be used in any of four directions since there is no specific top or bottom. There is an arrow on the side to guide capping straight walls. Just place the arrows in the same direction and touch them together as the caps are laid.

The fact that the cap can be turned any of four ways reduces dramatically the amount of cutting required on curves. For example, on an arc of about 25 feet, a standard trapezoidal or rectangular cap would require cutting every other cap or about 10 caps. With the Artisana[®] product, only four caps need to be cut. This again saves time, saw wear and tear, and diamond blades. See specifics on page three.

JOBSITE TOOL CHECKLIST

Hand tools

- Shovels
- Rakes
- Broom
- Tape measure
- 4-foot level
- Speed square

- Torpedo level
- Dead-blow hammer
- 2- or 3-pound sledge hammer
- Chisel
- Hand tamper
- String line
- Site level or laser level

Power tools

- Cut-off or chop saw with diamond blade
- Handheld grinder
- Compactor

Freestanding Wall Installation

WHEN TO USE A PATTERN FOR FREESTANDING WALLS

A versatile product, Artisana® walls can be built using a combination of 6- and 3-inch-high units, or with either 6- or 3-inch-high units alone. You can install the Artisana multi-height freestanding wall system in a random pattern using any combination of units. Just avoid vertical lines that span more than 18 inches in height.

If you are building a straight wall, use a pattern for inspiration or follow a pattern exactly. Pleasing random patterns can be built using an equal square footage of 3- and 6-inch-high units. Estimating formulas are based on using an equal square footage of units of each size in each height.

When using a pattern, begin at one edge laying the units as indicated. Install at least one repeat of the pattern to establish the pattern before proceeding to the next course.

If you are using either 6- or 3-inch-high units alone, you can use the patterns to produce a more random look with fewer stacked bonds. Estimating formulas are based on using an equal number of units of each size.

When using a pattern, begin at one edge laying the units as indicated. Install at least one repeat of the pattern to establish the pattern before proceeding to the next course.

PATTERNS

ARTISANA MULTIHEIGHT 18-INCH BY 7-FOOT, 4-INCH PATTERN

This illustrates a multiheight 8-inch-high by 7-foot, 4-inch-long repeating pattern.

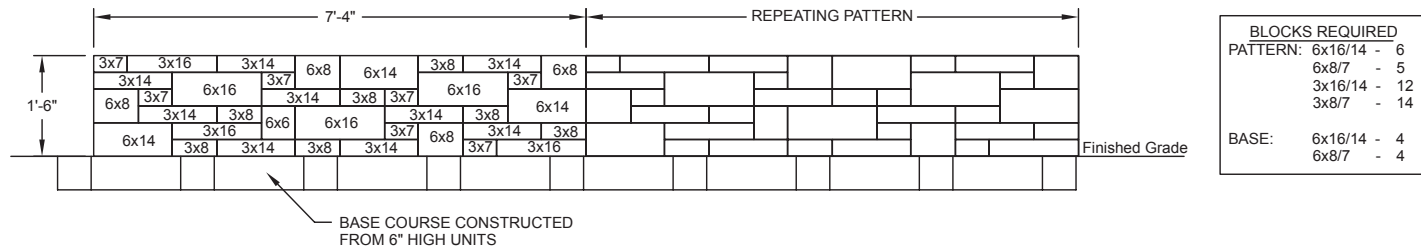

ARTISANA MULTIPIECE 18-INCH BY 9-FOOT, 8-INCH PATTERN — 6-INCH UNITS

This illustrates a multipiece 18-inch-high by 9-foot, 8-inch-long repeating pattern using 6-inch-high units.

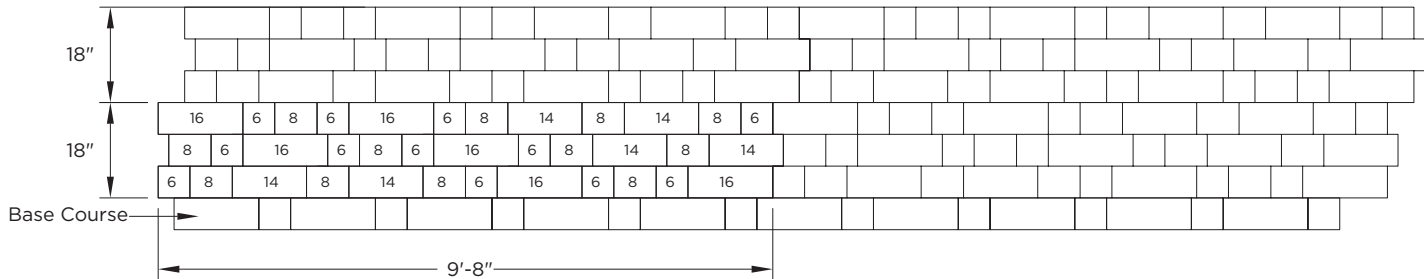

ARTISANA MULTIPIECE 18-INCH BY 9-FOOT, 8-INCH PATTERN — 3-INCH UNITS

This illustrates a multipiece 18-inch-high by 9-foot, 8-inch-long repeating pattern using 3-inch-high units.

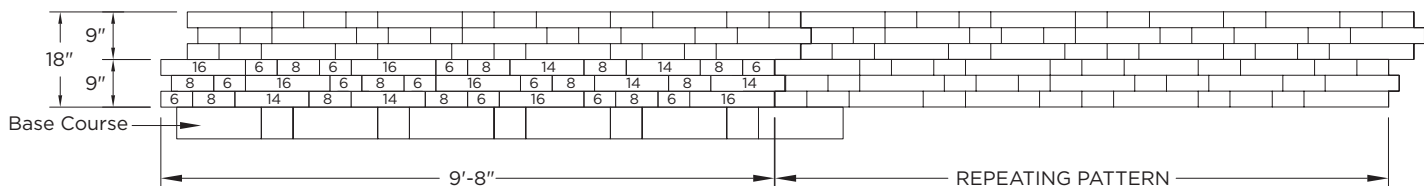

Capping a Wall

GETTING STARTED

- Always start capping a wall from the lowest elevation.
- Lay out caps prior to using adhesive.
- Use exterior-grade construction adhesive to glue caps.

STRAIGHT WALLS

Alternate short and long cap faces every other cap to achieve a straight row of caps. Place stamped arrows (1) on the side of caps in the same direction, either up or down, and touch them together as caps are laid. Always start capping from the lowest elevation.

Cap unit

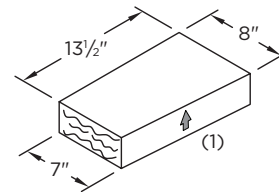

Straight wall

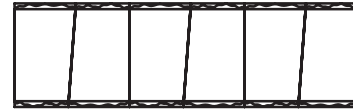

CURVED WALLS

The double-sided cap has a right-angle side and an offset-angle side. The caps can be used in any four directions since there is no specific top or bottom.

Cut caps to fit. Occasional cutting will be necessary for radii other than approximately 7'6".

Curved wall

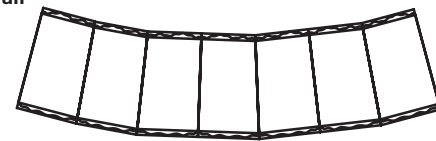

STEPPING UP CAPS

If a wall elevation changes, caps can be stacked where the wall steps up. Begin laying caps at the lowest elevation and work your way back toward the previous step up. Cut a cap unit to fit. Place the cut unit directly on top of the capped portion of the wall with the cut side hidden from view.

Stepping up

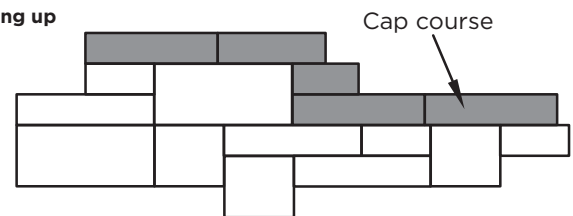

90° CORNERS

Mitered Corner

Place two caps together, arrows touching and facing in the same direction. Measure 1 1/2" in from corners as shown. Use straightedge to connect measurements and draw line. Carefully cut along line to preserve both sides of the cut.

Flip pieces "c" and "d" over to create corner.

Mitered corner

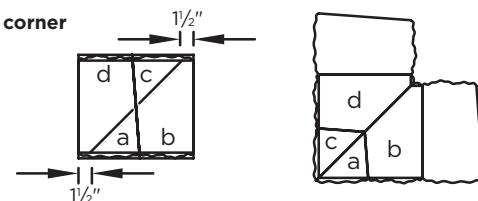

Alternate Corner

Cut 3"-high piece from column unit.

Cut 3"-high piece to 13" length.

Alternate corner

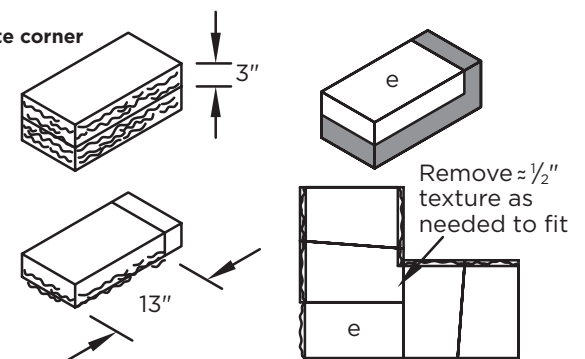

Freestanding Wall Installation

ENDING FREESTANDING WALL WITHOUT COLUMN

Use corner/column unit (a). Integrate end pieces into wall pattern as needed.

All dimensions shown are to contact points. Verify prior to construction. Construct base course using 6-inch-high units.

Cut 2-inch-wide strips from textured face of corner/column unit (b) as measured on smooth top and bottom surfaces and discard rear portion.

Cut across corner/column unit (c) to length as needed and discard unused portion.

Cut (d) similar to piece (c), then cut similar to piece (b). Remove locators as needed.

Glue all partial units to adjacent units using construction-grade adhesive.

Caps not shown for clarity.

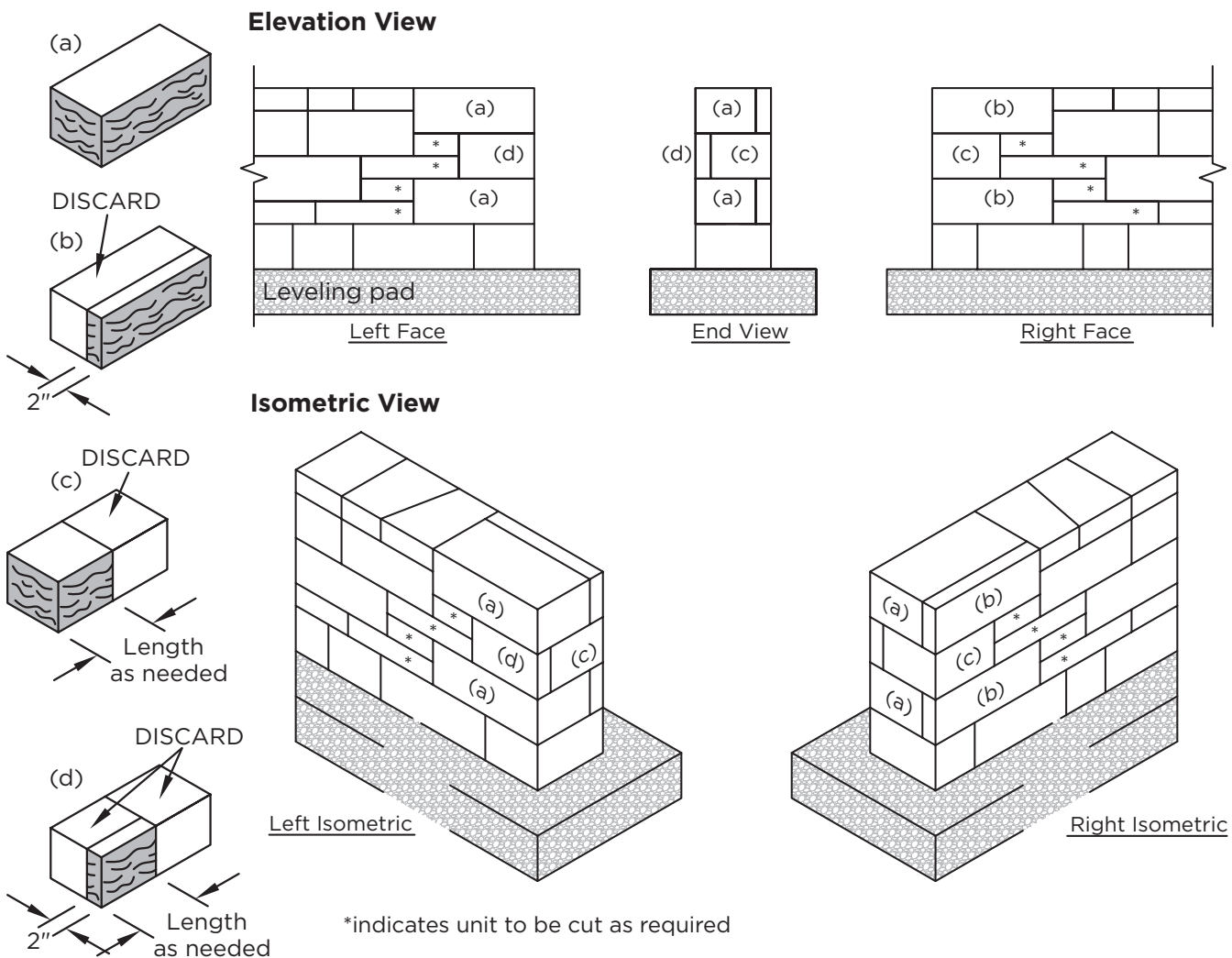

Freestanding Wall Installation

ENDING FREESTANDING WALL WITHOUT COLUMN

All dimensions shown are to contact points. Verify prior to construction. Construct base using the 6-inch-high units in combination.

End freestanding wall in pattern, making adjustments as needed. Use corner/column unit along with free-standing wall units and make cuts as indicated. Modify as needed.

Remove locators as needed.

Use construction-grade adhesive to glue cut units.

Caps not shown for clarity.

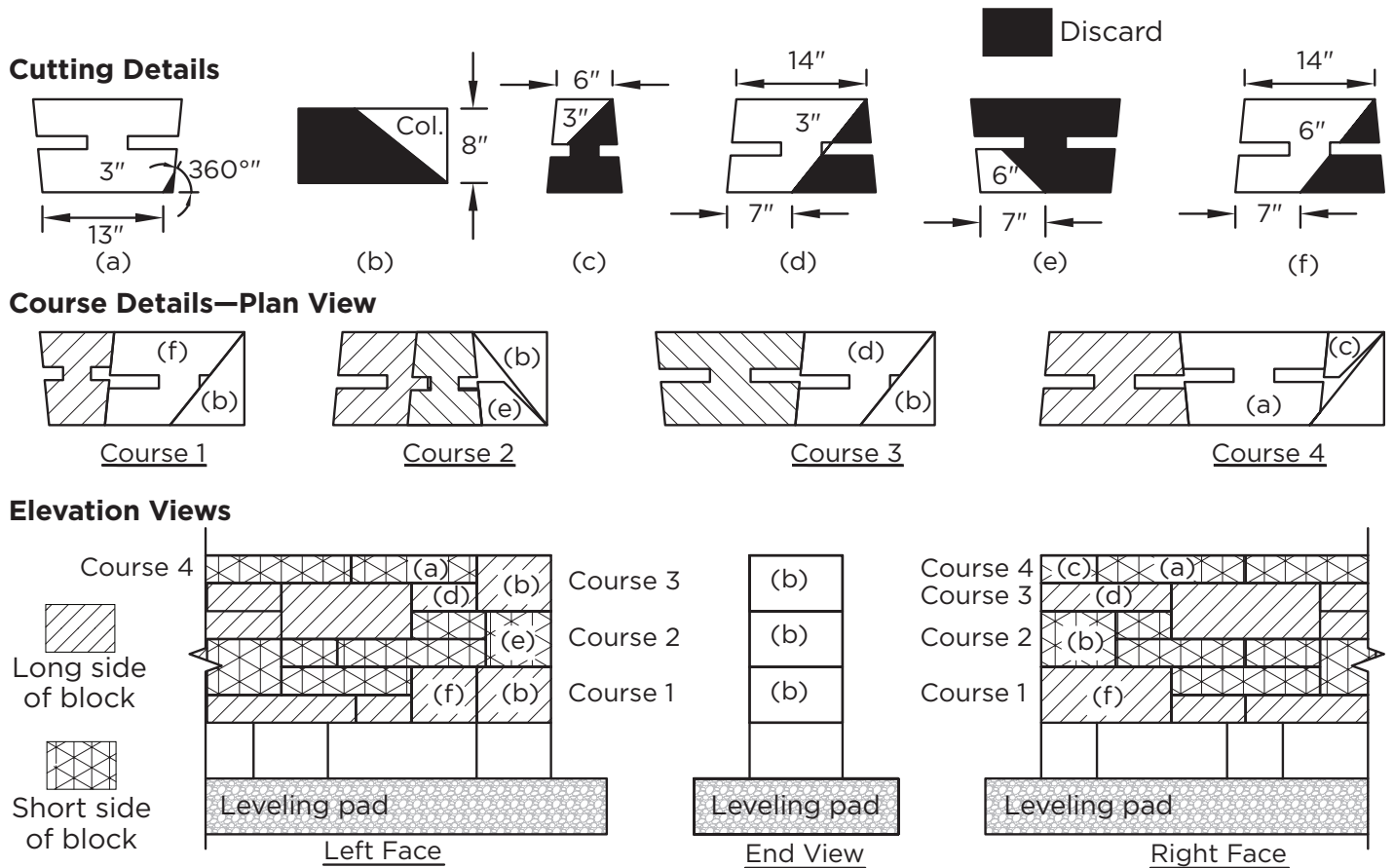

© 2010 Anchor Wall Systems, Inc. The Artisana® wall system is manufactured under license from Anchor Wall Systems, Inc. (AWS). The "Anchor Build Something Beautiful" logo and "Artisana" are trademarks of AWS. This wall system is covered by the AWS Limited Warranty. For a complete copy, visit your local dealer or see anchorwall.com.

Anchor Wall Systems, Inc., 5959 Baker Road, Suite 390, Minnetonka, MN 55345.
A&B0903

WIARTF 01/10